

***TB 9-6625-2271-50**

SUPERSEDED COPY DATED 5 MARCH 1998

DEPARTMENT OF THE ARMY TECHNICAL BULLETIN

CALIBRATION PROCEDURE FOR AUDIO ANALYZER BOONTON, MODEL 1120-S/10

Headquarters, Department of the Army, Washington, DC
21 August 2000

Approved for public release; distribution is unlimited

REPORTING OF ERRORS

You can help improve this publication by calling attention to errors and by recommending improvements and stating your reasons for the recommendations. Your letter or DA Form 2028, Recommended Changes to Publications, should be mailed directly to Commander, U.S. Army Aviation and Missile Command, ATTN: AMSAM-TMD-LP, Redstone Arsenal, AL 35898-5000. You may also contact this office electronically. FAX to DSN 788-2313 (commercial 256-842-2313). A reply will be furnished directly to you.

| | | Paragraph | Page |
|---------|------|--|-------------|
| SECTION | I. | IDENTIFICATION AND DESCRIPTION | |
| | | Test instrument identification..... | 1 2 |
| | | Forms, records, and reports..... | 2 2 |
| | | Calibration description | 3 2 |
| | II. | EQUIPMENT REQUIREMENTS | |
| | | Equipment required..... | 4 4 |
| | | Accessories required | 5 4 |
| | III. | CALIBRATION PROCESS | |
| | | Preliminary instructions..... | 6 5 |
| | | Equipment setup and internal calibration | 7 5 |
| | | Dc measurement accuracy..... | 8 7 |
| | | Ac measurement accuracy | 9 8 |
| | | Frequency measurement | 10 11 |
| | | Filters frequency accuracy..... | 11 12 |
| | | Distortion measurement accuracy..... | 12 12 |
| | | Output frequency accuracy..... | 13 15 |
| | | Output level | 14 16 |
| | | Output distortion | 15 19 |
| | | SINAD measurement accuracy | 16 20 |
| | | Final procedure..... | 17 22 |

*This bulletin supersedes TB 9-6625-2271-35, dated 5 March 1998.

**SECTION I
IDENTIFICATION AND DESCRIPTION**

1. Test Instrument Identification. This bulletin provides instructions for the calibration of Audio Analyzer, Boonton, Model 1120-S/10. The manufacturer's manual was used as the prime data source in compiling these instructions. The equipment being calibrated will be referred to as the TI (test instrument) throughout this bulletin.

a. Model Variations. None.

b. Time and Technique. The time required for this calibration is approximately 6 hours, using the dc and low frequency technique.

2. Forms, Records, and Reports

a. Forms, records, and reports required for calibration personnel at all levels are prescribed by TB 750-25.

b. Adjustments to be reported are designated (R) at the end of a sentence in which they appear. When adjustments are in tables, the (R) follows the designated adjustment. Report only those adjustments made and designated with (R).

3. Calibration Description. TI parameters and performance specifications which pertain to this calibration are listed in table 1.

Table 1. Calibration Description

| Test instrument parameters | Performance specifications |
|----------------------------|---|
| Dc level measurement | Range: 3, 30, 300 V FS Accuracy: $\pm 1\%$ or 3 counts whichever is greater |
| Ac level measurement | Range: 3, 30, 300 mV and 3, 30, 300 V Range: 50 Hz to 50 kHz (1 mV to 300 V) Accuracy: $\pm 1\%$ Range: 20 to 50 Hz and 50 to 100 kHz (1 mV to 300 V) Accuracy: $\pm 2\%$ Range: 10 to 20 Hz ¹ (1 mV to 300 V) Accuracy: $\pm 3\%$ Range: 10 Hz to 100 kHz ¹ (.3 mV to 300 V) Accuracy: ± 4 |
| Flatness | Range: 1 mV to 300V Range: 50 Hz to 50 kHz (1 mV to 300 V) Accuracy: $\pm 0.5\%$ Range: 20 to 50 Hz and 50 kHz to 100 kHz (1 mV to 300 V) Accuracy: $\pm 1.0\%$ Range: 10 to 20 Hz ¹ (1 mV to 300 V) Accuracy: $\pm 2.0\%$ |

See footnotes at end of table.

Table 1. Calibration Description - Continued

| Test instrument parameters | Performance specifications |
|----------------------------|---|
| Frequency counter | Range: 20 Hz to 500 kHz Sensitivity: 3 mV Accuracy: ± 1 ppm/yr +1 count |
| Audio filters | Range: 30 kHz low-pass Accuracy: ± 2 kHz Range: 80 kHz low-pass Accuracy: ± 4 kHz Range: 220 kHz low-pass Accuracy: ± 20 kHz Range: 400 Hz high-pass Accuracy: ± 40 Hz |
| Distortion measurement | Range: 10 Hz to 20 kHz Accuracy: ± 1 dB Range: 20 to 100 kHz Accuracy: ± 2 dB Input voltage range: 10 mV to 300 V |
| SINAD measurement | Frequency range: 10 Hz to 100 kHz Input voltage range: 10 mV to 300 V Display range: -120.00 to 0.00 dB ² Accuracy: ± 1 dB, 20 Hz to 20 kHz ± 2 dB, 10 Hz to 100 kHz |
| Output frequency | Range: 20 Hz to 140 kHz Accuracy: ± 10 ppm +1 count |
| Output level | Range: 10 Hz to 50 kHz, 0.6 mV to 16 V Accuracy: $\pm 0.5\%$ of setting +0.05% of range Range: 50 to 100 kHz, 0.6 mV to 16 V Accuracy: $\pm 1.0\%$ of setting +0.05% of range Range: 100 to 140 kHz, 0.6 mV to 16 V Accuracy: $\pm 1.5\%$ of setting +0.1% of range |
| Flatness | Ref 1 kHz (.30 mV to 8 V into 50 Ω) Accuracy: $\pm 0.5\%$; 10 Hz ¹ to 50 kHz |
| Output distortion | Range: 10 Hz to 20 kHz, 80 kHz bandwidth Accuracy: $\pm 0.01\%$ (<-80 dB) Range: 20 to 50 kHz, 220 kHz bandwidth Accuracy: $\pm 0.02\%$ (<-74 dB) Range: 50 to 100 kHz, 500 kHz bandwidth Accuracy: $\pm 0.056\%$ (<-65 dB) Range: 100 to 140 kHz, 500 kHz bandwidth Accuracy: $\pm 0.1\%$ (<-60 dB) |

¹Not checked below 20 Hz.

²Not verified below -30 dB.

**SECTION II
EQUIPMENT REQUIREMENTS**

4. Equipment Required. Table 2 identifies the specific equipment to be used in this calibration procedure. This equipment is issued with Secondary Reference Calibration Standards Set NSN 4931-00-621-7878. Alternate items may be used by the calibrating activity. The items selected must be verified to perform satisfactorily prior to use and must bear evidence of current calibration. The equipment must meet or exceed the minimum use specifications listed in table 2. The accuracies listed in table 2 provide a four-to-one ratio between the standard and TI.

5. Accessories Required. The accessories required for the calibration are common usage accessories, issued as indicated in paragraph 4 above and are not listed in this calibration procedure.

Table 2. Minimum Specifications of Equipment Required

| Common name | Minimum use specifications | Manufacturer and model (part number) |
|--------------------------------|--|---|
| AC MEASUREMENT STANDARD | Range: 20 Hz to 120 kHz 2.97 mV to 16.256 V Accuracy: $\pm 1.25\%$ | John Fluke, Model 5790A (5790A) |
| CALIBRATOR | Range: 3 to 300 V dc Accuracy: $\pm 0.2755\%$ Range: 20 Hz to 100 kHz, 3 mV to 300 V Accuracy: $\pm 0.25\%$ | John Fluke, Model 5700A/CT (p/o MIS-35947); w/power amplifier, John Fluke, Model 5725A (5725A); w/ac divider, John Fluke, Model 7405A-4207 (7405A-4207) |
| MULTIMETER | ACV range: 20 Hz to 100 kHz, 1 mV to 3 V rms Accuracy: $\pm 0.175\%$ | Hewlett-Packard, Model 3458A/E02 (3458A/E02) |
| FREQUENCY COUNTER | Range: 20 Hz to 140 kHz Accuracy: ± 2.5 ppm | Hewlett-Packard, Model 5345A (MIS-28754/1 Type 1) |
| SPECTRUM ANALYZER ¹ | Range: 1 kHz <-75 dBm | Hewlett-Packard, Model 3585A (MIS-35951) |
| SYNTHESIZER/FUNCTION GENERATOR | Frequency range: 1200 Hz to 80 kHz Attenuator Accuracy: ± 0.25 dB @ 1200 Hz ± 0.5 dB @ 80 kHz | Hewlett-Packard, Model 3325A (MIS-35932) |
| TIME/FREQUENCY WORKSTATION | Range: 10 MHz Accuracy: ± 0.25 ppm | AUTEK Systems Corp., Model 620 (MIS-38946) |

¹Used only for adjustments.

**SECTION III
CALIBRATION PROCESS**

6. Preliminary Instructions

a. The instructions outlined in paragraphs 6 and 7 are preparatory to the calibration process. Personnel should become familiar with the applicable sections before beginning the calibration.

b. Items of equipment used in this procedure are referenced within the text by common name as listed in table 2.

c. Unless otherwise specified, verify the result of each test and, whenever the test requirement is not met, take corrective action before continuing with the calibration. Adjustments required to calibrate the TI are included in this procedure. Additional maintenance information is contained in the manufacturer's manual for this TI.

d. Unless otherwise specified, all controls and control settings refer to the TI.

7. Equipment Setup and Internal Calibration.

WARNING

HIGH VOLTAGE is used or exposed during the performance of this calibration. DEATH ON CONTACT may result if personnel fail to observe safety precautions. REDUCE OUTPUT(S) to minimum after each set within the performance check where applicable.

a. Remove TI top cover and assure A4S1 switch segments are all in the up position as shown in figure 1. Note initial settings (if not up) for return after completion of procedure.

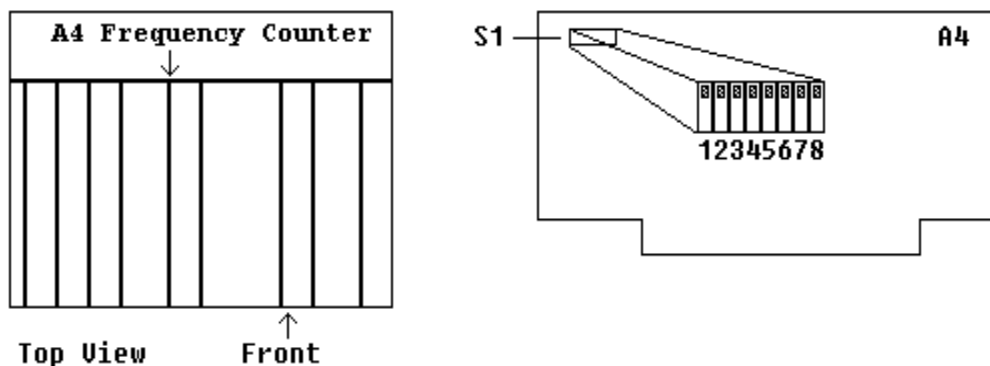

Figure 1. A4S1 - switch location.

b. Replace top cover and connect TI to a 115 V ac source.

TB 9-6625-2271-50

- c. Set **LINE** switch to **ON** and allow 1 hour for warmup.
- d. Connect calibrator **OUTPUT HI** and **LO** to TI **INPUT HIGH** and **LOW** using balanced cable supplied with TI.

NOTE

If balanced cable is not available then connect as shown in figure 2 for this and all future reference to balanced cable.

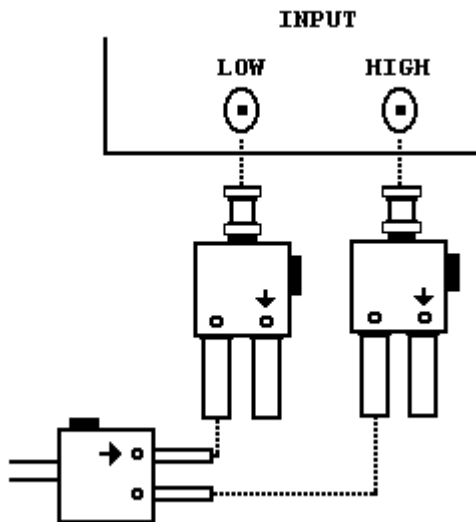

Figure 2. Input connection.

- e. Set calibrator for a 3 V, 1 kHz output.
- f. Press **LCL INIT** key. Press **INPUT FLOAT** key and verify **INPUT FLOAT** indicator is illuminated.
- g. Press **SPCL** key and enter **20 ENTER** using **DATA ENTRY** keys. Allow sufficient time for ac self-calibration to complete before continuing.

NOTE

Ac self-calibration is being performed. Verify no error codes are displayed on TI.

- h. Disconnect calibrator from TI.
- i. Connect TI **INPUT LOW** to **INPUT HIGH** using a short cable.
- j. Press **SPCL** key and enter **23 ENTER** using **DATA ENTRY** keys. Allow sufficient time for dc zero calibration to complete before continuing.

NOTE

Dc offset self-calibration is being performed. Verify no error codes are displayed on TI.

k. Connect calibrator **OUTPUT HI** and **LO** to TI **INPUT HIGH** and **LOW** using balanced cable.

l. Set calibrator for a 3 V dc output.

m. Press **SPCL** key and enter **24 ENTER** using **DATA ENTRY** keys. Allow sufficient time for dc calibration to complete before continuing.

NOTE

Dc self-calibration is being performed. Verify no error codes are displayed on TI.

n. Set calibrator output to standby.

8. Dc Measurement Accuracy

a. Performance Check

(1) Connect calibrator **OUTPUT HI** and **LO** to TI **INPUT HIGH** and **LOW** using balanced cable.

(2) Press keys as listed in (a) through (c) below:

(a) **LCL INIT**

(b) **INPUT FLOAT** (assure illumination)

(c) **FILTERS DC**

(3) If TI does not indicate between -0.003 and 0.003 V perform **b** below.

(4) Set calibrator for a 3 V dc output. TI will indicate between 2.97 and 3.03 V.

(5) Repeat technique of (4) above using calibrator output settings and TI indications listed in table 3 below.

Table 3. Dc Measurement

| Calibrator output settings (V dc) | Test instrument indications (V) | |
|--------------------------------------|------------------------------------|-------|
| | Min | Max |
| 30 | 29.7 | 30.3 |
| 300 | 297 | 303 |
| -300 | -303 | -297 |
| -30 | -30.3 | -29.7 |
| -3 | -3.03 | -2.97 |

b. Adjustments. No specific dc input adjustments can be made; however, misalignment of balance adjustments located after ac measurement accuracy can adversely affect this parameter.

TB 9-6625-2271-50

9. Ac Measurement Accuracy

a. Performance Check

(1) Connect calibrator **OUTPUT HI** and **LO** to TI **INPUT HIGH** and **LOW** using balanced cable.

(2) Press **LCL INIT** key. Press **INPUT FLOAT** key and verify **INPUT FLOAT** indicator is illuminated.

(3) Set calibrator for a 3 mV, 1 kHz output. If TI indication is not between 2.970 and 3.030 mV, perform **b** below.

(4) Repeat technique of (3) above using calibrator output settings and TI indications listed in table 4.

Table 4. Ac Measurement Accuracy

| Calibrator output settings | | Test instrument indications (V) | |
|----------------------------|-----------|---------------------------------|---------|
| Amplitude (V) | Frequency | Min | Max |
| .03 | 1 kHz | 29.70 m | 30.30 m |
| .3 | 1 kHz | 297.0 m | 303.0 m |
| 3 | 1 kHz | 2.970 | 3.030 |
| 30 | 1 kHz | 29.70 | 30.30 |
| 300 | 1 kHz | 297.0 | 303.0 |
| .003 | 50 Hz | 2.970 m | 3.030 m |
| .03 | 50 Hz | 29.70 m | 30.30 m |
| .3 | 50 Hz | 297.0 m | 303.0 m |
| 3 | 50 Hz | 2.970 | 3.030 |
| 30 | 50 Hz | 29.70 | 30.30 |
| 300 | 50 Hz | 297.0 | 303.0 |
| .003 | 49 Hz | 2.940 m | 3.060 m |
| .03 | 49 Hz | 29.40 m | 30.60 m |
| .3 | 49 Hz | 294.0 m | 306.0 m |
| 3 | 49 Hz | 2.940 | 3.060 |
| 30 | 49 Hz | 29.40 | 30.60 |
| 200 | 49 Hz | 196.0 | 204.0 |
| .003 | 20 Hz | 2.940 m | 3.060 m |
| .03 | 20 Hz | 29.40 m | 30.60 m |
| .3 | 20 Hz | 294.0 m | 306.0 m |
| 3 | 20 Hz | 2.940 | 3.060 |
| 30 | 20 Hz | 29.40 | 30.60 |
| 200 | 20 Hz | 196.0 | 204.0 |

Table 4. Ac Measurement Accuracy - Continued

| Calibrator output settings | | Test instrument indications (V) | |
|-------------------------------|-----------|------------------------------------|---------|
| Amplitude (V) | Frequency | Min | Max |
| 3 | 100 kHz | 2.940 | 3.060 |
| 30 | 100 kHz | 29.40 | 30.60 |
| 200 | 100 kHz | 196.0 | 204.0 |
| .003 | 51 kHz | 2.940 m | 3.060 m |
| .03 | 51 kHz | 29.40 m | 30.60 m |
| .3 | 51 kHz | 294.0 m | 306.0 m |

b. Adjustments

NOTE

All adjustments interact and must be performed in their entirety. After making adjustments in this section, it is necessary to return to beginning of procedure.

- (1) Connect spectrum analyzer input to TI **MONITOR** (rear panel).
- (2) Connect TI **OUTPUT HIGH** to **INPUT HIGH** and **LOW** using tee connector and two cables.
- (3) Press keys and enter values using **DATA ENTRY** keys as listed in (a) through (g) below:
 - (a) **LCL INIT.**
 - (b) **INPUT FLOAT** (assure illumination).
 - (c) **SPCL.**
 - (d) **28 ENTER.**
 - (e) **SOURCE LEVEL.**
 - (f) **3 V.**
 - (g) **ANALYZER LEVEL.**
- (4) Adjust spectrum analyzer controls to observe a 1 kHz signal.
- (5) Alternately adjust A0R29 and A0C35 (fig. 3) for minimum indication on spectrum analyzer (R).
- (6) Press **SPCL** key and enter **27 ENTER** using **DATA ENTRY** keys. Adjust A0R12 (fig. 3) for minimum indication on spectrum analyzer.
- (7) If <-75 dB was not achieved in (5) or (6) above, then alternately adjust A0C5, A0C10, and A0R12 (fig. 3) for minimum indication on spectrum analyzer (R).

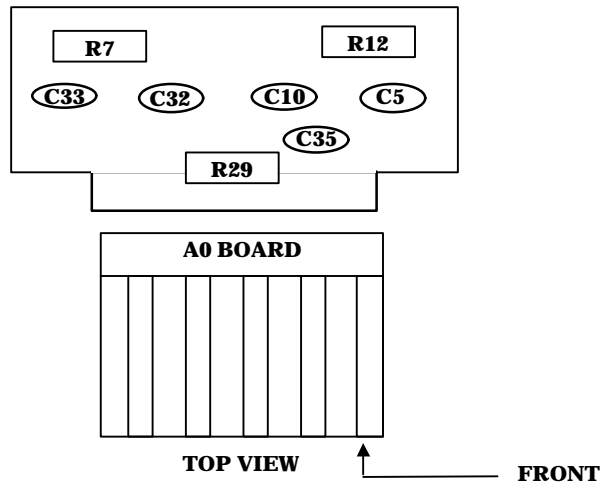

Figure 3. Input board - adjustment locations.

- (8) Press **SPCL** key and enter **26 ENTER** using **DATA ENTRY** keys.
- (9) Adjust A0R7 (fig. 3) for minimum indication on spectrum analyzer (R).
- (10) If <-75 dB was not achieved in (9) above then alternately adjust A0C32, A0C33, and A0R7 (fig. 3) for minimum indication on spectrum analyzer (R).
- (11) Disconnect spectrum analyzer from equipment setup.
- (12) Disconnect TI **OUTPUT HIGH** from **INPUT HIGH** and **LOW**.
- (13) Connect TI **OUTPUT HIGH** to **INPUT HIGH** and connect **OUTPUT LOW** to **INPUT LOW**.
- (14) Press keys and enter values using **DATA ENTRY** keys as listed in (a) through (l) below:
 - (a) **LCL INIT.**
 - (b) **SOURCE LEVEL.**
 - (c) **3 V.**
 - (d) **SOURCE FREQ.**
 - (e) **100 kHz.**
 - (f) **INPUT FLOAT** (assure illumination).
 - (g) **SPCL.**
 - (h) **17 ENTER.**
 - (i) **28 ENTER.**
 - (j) **RATIO.**
 - (k) **SPCL.**
 - (l) **27 ENTER.**

- (15) Adjust A0C5 (fig. 3) for a 100.0 percent indication on TI (R).
- (16) Press **SPCL** key and enter **26 ENTER** using **DATA ENTRY** keys.
- (17) Adjust A0C32 (fig. 3) for a 100.0 percent indication on TI (R).
- (18) Reverse **INPUT HIGH** and **LOW** connections and repeat (13) above.
- (19) Adjust A0C10 (fig. 3) for a 100.0 percent indication on TI (R).
- (20) Press **SPCL** key and enter **26 ENTER** using **DATA ENTRY** keys.
- (21) Adjust A0C33 (fig. 3) for a 100.0 percent indication on TI (R).

10. Frequency Measurement

a. Performance Check

- (1) Connect synthesizer/function generator **SIGNAL** to TI **INPUT HIGH**.
- (2) Connect time/frequency workstation **OUTPUT 10 MHz** to synthesizer/function generator **EXT REF IN 10 MHz** (rear panel).
- (3) Press keys as listed in (a) and (b) below.
 - (a) **LCL INIT.**
 - (b) **ANALYZER FREQ.**
- (4) Set synthesizer/function generator for a sinewave, 100 Hz, 3 mV output. TI will indicate between 99.99 and 100.01 Hz
- (5) Repeat technique of (4) above using synthesizer/function generator settings and TI indications listed in table 5.

Table 5. Frequency Accuracy

| Synthesizer/function generator settings | | Test instrument frequency indications | |
|---|------|---------------------------------------|-------------|
| (kHz) | (V) | Min | Max |
| 1 | .003 | 999.9 Hz | 1000.1 Hz |
| 100 | .003 | 99.99 kHz | 100.01 kHz |
| 40 Hz | 1.5 | 39.999 Hz | 40.001 Hz |
| 190 Hz | 1.5 | 189.999 Hz | 190.001 Hz |
| 210 Hz | 1.5 | 209.99 Hz | 210.01 Hz |
| 1.9 | 1.5 | 1899.99 Hz | 1900.01 Hz |
| 2.1 | 1.5 | 2099.9 Hz | 2100.1 Hz |
| 19 | 1.5 | 18999.9 Hz | 19000.1 Hz |
| 21 | 1.5 | 20.999 kHz | 21.001 kHz |
| 190 | 1.5 | 189.999 kHz | 190.001 kHz |
| 210 | 1.5 | 209.99 kHz | 210.01 kHz |
| 490 | 1.5 | 489.99 kHz | 490.01 kHz |

- b. Adjustments.** No adjustments can be made.

11. Filters Frequency Accuracy

a. Performance Check

- (1) Connect calibrator **OUTPUT HI** and **LO** to TI **INPUT HIGH** and **LOW** using balanced cable.
- (2) Press keys as listed in (a) through (c) below.
 - (a) **LCL INIT.**
 - (b) **INPUT FLOAT.**
 - (c) **FILTERS LP 30.**
- (3) Set calibrator for a 1 V, 1 kHz output.
- (4) Press TI **RATIO** key to establish reference at 1 kHz.
- (5) Set calibrator frequency to 27.99 kHz. TI will indicate >70.7 percent.
- (6) Set calibrator frequency to 32.01 kHz. TI will indicate <70.7 percent.
- (7) Set calibrator frequency to 1 kHz.
- (8) Press TI **RATIO** key. **RATIO** light will be extinguished.
- (9) Press TI **FILTERS LP 80** key then **RATIO** key to establish reference at 1 kHz.
- (10) Set calibrator frequency to 75.99 kHz. TI will indicate >70.7 percent.
- (11) Set calibrator frequency to 84.01 kHz. TI will indicate <70.7 percent.
- (12) Set calibrator frequency to 1 kHz.
- (13) Press TI **RATIO** key. **RATIO** light will be extinguished.
- (14) Press TI **FILTERS LP 220** key then **RATIO** key to establish reference at 1 kHz.
- (15) Set calibrator frequency to 199.9 kHz. TI will indicate >70.7 percent.
- (16) Set calibrator frequency to 240.1 kHz. TI will indicate <70.7 percent.

b. Adjustments. No adjustments can be made.

12. Distortion Measurement Accuracy

a. Performance Check

- (1) Connect TI **OUTPUT HIGH** to **INPUT HIGH** using short shielded cable.
- (2) Connect calibrator **OUTPUT HI** and **LO** to TI **INPUT LOW** using calibrator ac divider (1000:1).
- (3) Press keys and enter values using **DATA ENTRY** keys as listed in (a) through (h) below:

- (a) **LCL INIT.**
- (b) **INPUT FLOAT** (assure illumination).
- (c) **SOURCE FREQ.**
- (d) **21 Hz.**
- (e) **SOURCE LEVEL.**
- (f) **1 V.**
- (g) **ANALYZER DIST.**
- (h) **dB.**

(4) Set calibrator for a 1 V, 222 Hz output. If TI indication is not between -59 and -61 dB, perform **b** below.

(5) Press TI **SOURCE FREQ** key and enter **1 kHz** using **DATA ENTRY** keys. If TI indication is not between -59 and -61 dB, perform **b** below.

(6) Repeat technique of (5) using TI **SOURCE FREQ** settings and indications listed in table 6.

Table 6. Distortion Measurement Accuracy at -60 dB

| Test instrument SOURCE FREQ settings (kHz) | Test instrument indications (dB) | |
|--|-------------------------------------|-----|
| | Min | Max |
| 19.99 | -61 | -59 |
| 21 | -62 | -58 |
| 50 | -62 | -58 |
| 100 | -62 | -58 |

(7) Set calibrator for a 10 V, 222 Hz output. Repeat technique of (5) above using TI **SOURCE FREQ** settings and indications listed in table 7.

Table 7. Distortion Measurement Accuracy at -40 dB

| Test instrument SOURCE FREQ settings | Test instrument indications (dB) | |
|---|-------------------------------------|-----|
| | Min | Max |
| 21 Hz | -41 | -39 |
| 1 kHz | -41 | -39 |
| 19.99 kHz | -41 | -39 |
| 21 kHz | -42 | -38 |
| 50 kHz | -42 | -38 |
| 100 kHz | -42 | -38 |

- (8) Set calibrator output to standby and remove ac divider from equipment hookup.
- (9) Connect calibrator **OUTPUT HI** and **LO** to TI **INPUT LOW**.

TB 9-6625-2271-50

(10) Set calibrator for a .1 V, 222 Hz output. Repeat technique of (5) above using TI **SOURCE FREQ** settings and indications listed in table 8.

Table 8. Distortion Measurement Accuracy at -20 dB

| Test instrument SOURCE FREQ settings | Test instrument indications (dB) | |
|---|-------------------------------------|-----|
| | Min | Max |
| 21 Hz | -21 | -19 |
| 1 kHz | -21 | -19 |
| 19.99 kHz | -21 | -19 |
| 21 kHz | -22 | -18 |
| 50 kHz | -22 | -18 |
| 100 kHz | -22 | -18 |

b. Adjustments

NOTE

The adjustments provided are for the notch filter. These adjustments will not affect distortion accuracy; however, capability will be enhanced by lowering residual distortion. Perform the following only if TI indications are high.

- (1) Connect TI **OUTPUT HIGH** to **INPUT HIGH** and **OUTPUT LOW** to **INPUT LOW**.
- (2) Press keys and enter values using **DATA ENTRY** keys as listed in (a) through (d) below:
 - (a) **LCL INIT.**
 - (b) **SOURCE LEVEL.**
 - (c) **3 V.**
 - (d) **ANALYZER DIST.**
- (3) Adjust A2R57 and A2R58 (fig. 4) for minimum distortion indication on TI.

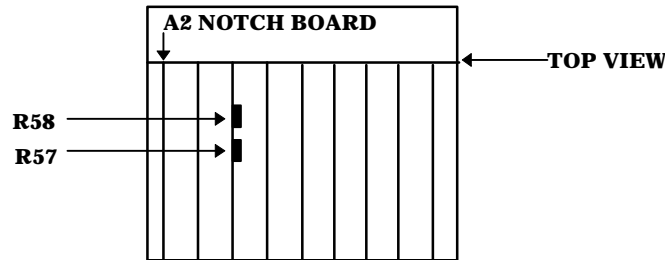

Figure 4. Distortion measurement - adjustment locations.

13. Output Frequency Accuracy

a. Performance Check

- (1) Connect TI **OUTPUT HIGH** to frequency counter **CHANNEL A** input.
- (2) Press keys and enter values using **DATA ENTRY** keys as listed in (a) through (e) below:
 - (a) **LCL INIT.**
 - (b) **SOURCE LEVEL.**
 - (c) **1 V.**
 - (d) **SOURCE FREQ.**
 - (e) **21.111 Hz.**
- (3) Adjust frequency counter controls for a stable display. If frequency counter indication is not between 21.110 and 21.112 Hz, perform **b** below.
- (4) Enter **322.22 Hz** using **DATA ENTRY** keys. Frequency counter will indicate between 322.21 and 322.23 Hz.
- (5) Repeat technique of (4) above using TI **SOURCE FREQ** and frequency counter indications listed in table 9.

Table 9. Output Frequency Accuracy

| Test instrument SOURCE FREQ (Hz) | Frequency counter indications (Hz) | |
|---|---------------------------------------|--------|
| | Min | Max |
| 433.33 | 433.32 | 433.34 |
| 5444.4 | 5444.3 | 5444.5 |
| 6555.5 | 6555.4 | 6555.6 |
| 76666 | 76665 | 76667 |
| 87777 | 87776 | 87778 |
| 98888 | 98887 | 98889 |
| 99999 | 99998 | 100001 |
| 140000 | 139999 | 140001 |

b. Adjustments

- (1) Connect time/frequency workstation **OUTPUT 10 MHz** to TI rear panel **X CLOCK** input.

TB 9-6625-2271-50

(2) Remove top cover and set A4S1 (fig. 5) switch positions 7 and 8 to open (down) and press **LCL INIT** key.

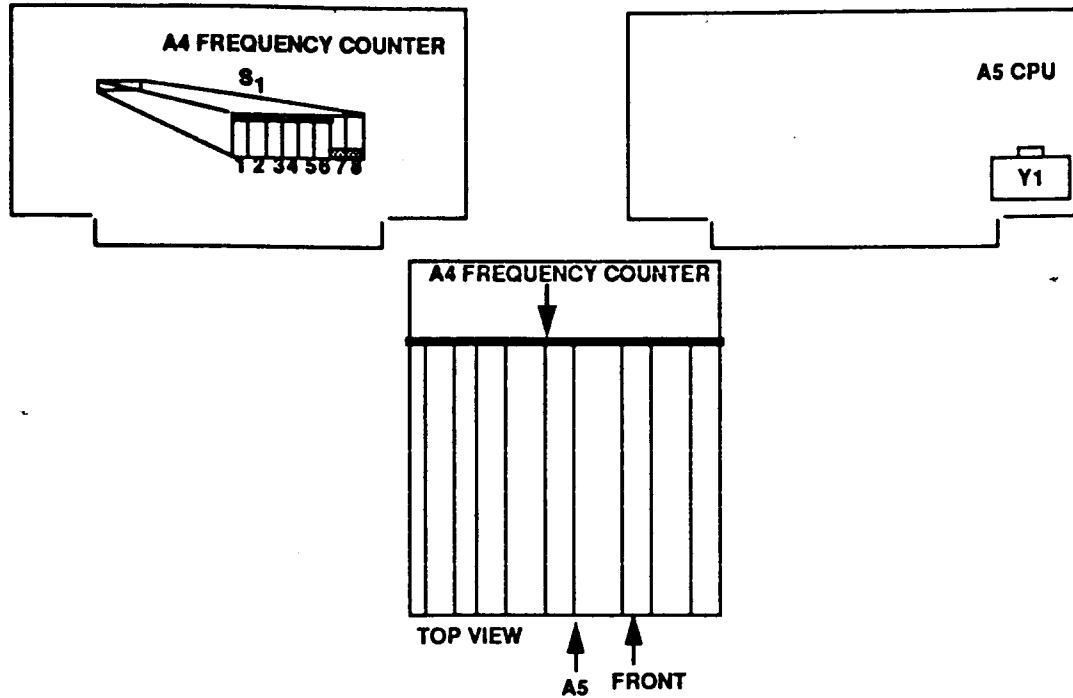

Figure 5. Time base accuracy - adjustment locations.

(3) Remove cover screw from A5 CPU Y1 (fig. 5) and adjust internal slotted screw for a TI indication of 10000.00 kHz (± 1 count) (R).

(4) Reset A4 FREQUENCY COUNTER S1 (fig. 5) switch positions 7 and 8 to the closed (up) position.

(5) Replace A5 CPU Y1 (fig. 5) cover screw and TI top cover.

14. Output Level

a. Performance Check

(1) Connect TI **OUTPUT HIGH** to ac measurement standard **INPUT 2 HI** and **LO**. Setup ac measurement standard to measure levels at **INPUT 2**.

(2) Press keys and enter values using **DATA ENTRY** keys as listed in (a) through (e) below:

(a) **LCL INIT**.

- (b) **SOURCE LEVEL.**
- (c) **3 mV.**
- (d) **SOURCE FREQ.**
- (e) **1 kHz.**

(3) If ac measurement standard indication is not between 2.97 and 3.03 mV ac, perform **b** below.

(4) Repeat technique of (2)(b) through (e) and (3) above using TI **SOURCE** settings and ac measurement standard indications listed in table 10.

Table 10. Level Accuracy

| Test instrument SOURCE settings | | Ac measurement standard indications | |
|---|-------------|--|-----------|
| LEVEL | FREQ | Min | Max |
| 3 mV | 90 kHz | 2.955 mV | 3.045 mV |
| 3 mV | 120 kHz | 2.925 mV | 3.075 mV |
| 30 mV | 1 kHz | 29.835 mV | 30.165 mV |
| 30 mV | 90 kHz | 29.685 mV | 30.315 mV |
| 30 mV | 120 kHz | 29.52 mV | 30.48 mV |
| 300 mV | 1 kHz | 298.35 mV | 301.65 mV |
| 300 mV | 90 kHz | 296.85 mV | 303.15 mV |
| 300 mV | 120 kHz | 295.2 mV | 304.8 mV |
| 3 V | 1 kHz | 2.9835 V | 3.0165 V |
| 3 V | 90 kHz | 2.9685 V | 3.0315 V |
| 3 V | 120 kHz | 2.952 V | 3.048 V |
| 16 V | 1 kHz | 15.912 V | 16.088 V |
| 16 V | 90 kHz | 15.832 V | 16.168 V |
| 16 V | 120 kHz | 15.744 V | 16.256 V |

(5) Press keys and enter values using **DATA ENTRY** keys as listed in (a) through (g) below:

- (a) **LCL INIT.**
- (b) **SOURCE LEVEL.**
- (c) **3 mV.**
- (d) **SOURCE FREQ.**
- (e) **1 kHz.**
- (f) **SPCL.**
- (g) **75 ENTER.**

(6) Record the ac measurement standard indication as reference.

TB 9-6625-2271-50

(7) Press TI **SOURCE FREQ** key and enter **20 Hz** using **DATA ENTRY** keys. The ac measurement standard indication will be within ± 0.5 percent of reference recorded in (6) above.

(8) Repeat (7) above using TI **SOURCE FREQ** settings as listed in table 11.

Table 11. Output Flatness

| Test instrument SOURCE FREQ settings (Hz) |
|--|
| 40 |
| 80 |
| 160 |
| 320 |
| 640 |
| 1200 |
| 2000 |
| 4000 |
| 8000 |
| 16000 |
| 32000 |
| 50000 |

b. Adjustments

(1) Press keys and enter values using **DATA ENTRY** keys as listed in (a) through (d) below:

- (a) **SOURCE FREQ.**
- (b) **1 kHz.**
- (c) **SOURCE LEVEL.**
- (d) **3.000 V.**

(2) Adjust A6R23 (fig. 6) for a multimeter indication of 3.000 V.

(3) Enter **511 mV** using **DATA ENTRY** keys and record multimeter indication.

(4) Enter **512 mV** using **DATA ENTRY** keys and adjust A7R21 (fig. 6) for a multimeter indication of 1 mV greater than that recorded in (3) above (R).

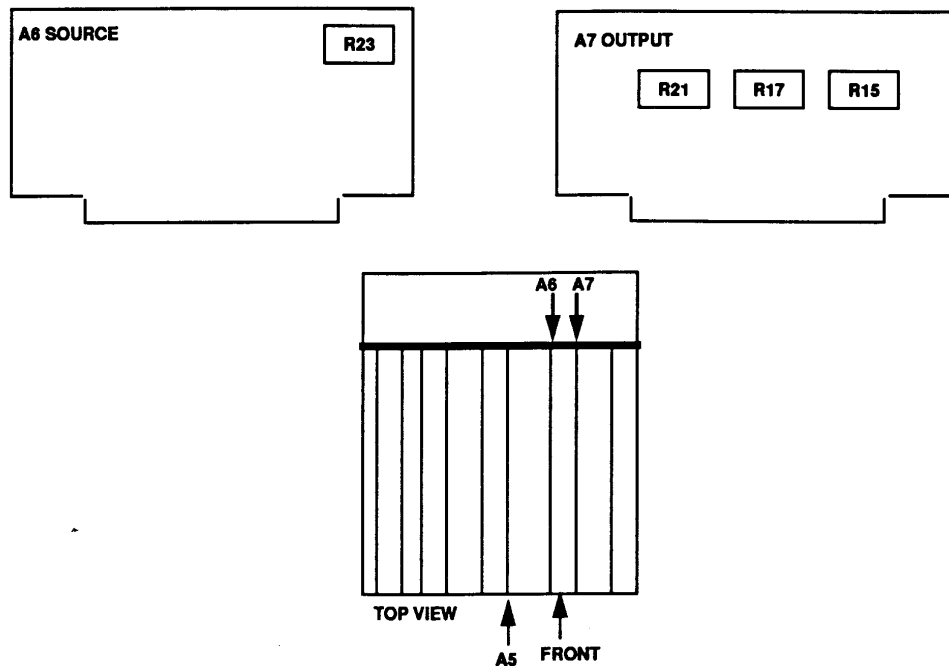

Figure 6. Output level - adjustment locations.

- (5) Enter **1.023 V** using **DATA ENTRY** keys and record multimeter indication.
- (6) Enter **1.024 V** using **DATA ENTRY** keys and adjust A7R17 (fig. 6) for a multimeter indication of 1 mV greater than that recorded in (5) above (R).
- (7) Enter **2.047 V** using **DATA ENTRY** keys and record multimeter indication.
- (8) Enter **2.048 V** using **DATA ENTRY** keys and adjust A7R15 (fig. 6) for a multimeter indication of 1 mV greater than that recorded in (7) above (R).
- (9) Enter **3.000 V** using **DATA ENTRY** keys and adjust A6R23 (fig. 6) for a multimeter indication of 3.000 V (R).

15. Output Distortion

a. Performance Check

- (1) Connect TI **OUTPUT HIGH** to **INPUT HIGH** using a short shielded cable.
- (2) Press keys and enter values using **DATA ENTRY** keys as listed in (a) through (h) below:
 - (a) **LCL INIT.**
 - (b) **SOURCE LEVEL.**
 - (c) **1 V.**
 - (d) **SOURCE FREQ.**
 - (e) **20 Hz.**

TB 9-6625-2271-50

- (f) **ANALYZER DIST.**
- (g) **SPCL.**
- (h) **75 ENTER.**

(3) If TI indication is not <.01 percent, perform **b** below.

(4) Press TI **SOURCE FREQ** key and enter **40 Hz** using **DATA ENTRY** keys. If TI indication is not <.01 percent, perform **b** below.

(5) Repeat (4) above using TI **SOURCE FREQ** settings listed in table 12.

Table 12. Output Distortion

| Test instrument SOURCE FREQ settings (Hz) |
|--|
| 80 |
| 160 |
| 320 |
| 640 |
| 1280 |
| 2560 |
| 5120 |
| 10240 |
| 19990 |

(7) Enter **21 kHz** using **DATA ENTRY** keys. If TI indication is not <.02 percent, perform **b** below.

(8) Enter **42 kHz** using **DATA ENTRY** keys. If TI indication is not <.02 percent, perform **b** below.

(9) Enter **84 kHz** using **DATA ENTRY** keys. If TI indication is not <.056 percent, perform **b** below.

(10) Enter **99 kHz** using **DATA ENTRY** keys. If TI indication is not <.056 percent, perform **b** below.

b. Adjustments. No specific adjustments are provided for the output circuitry of TI. The adjustments listed in paragraph **12**, Distortion Measurement Accuracy, could cause a failure of this test. If distortion indications are only slightly high, perform paragraph **12b** then perform paragraphs **12a** and **15**.

16. SINAD Measurement Accuracy

a. Performance Check

(1) Connect equipment as shown in figure 7.

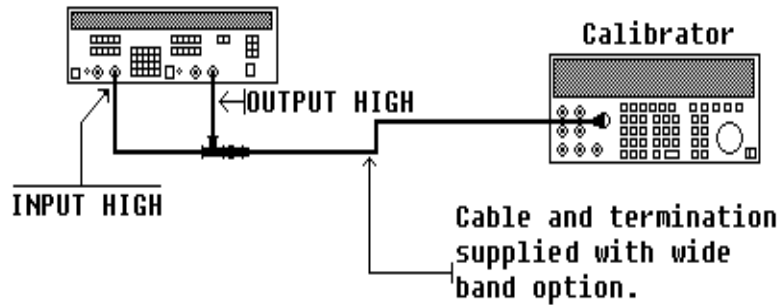

Figure 7. SINAD measurement.

(2) Press keys and enter values using **DATA ENTRY** keys as listed in (a) through (j) below:

- (a) **LCL INIT.**
- (b) **SOURCE LEVEL.**
- (c) **1 V.**
- (d) **SOURCE FREQ.**
- (e) **600 Hz.**
- (f) **SPCL.**
- (g) **75 ENTER.**
- (h) **ANALYZER SINAD.**
- (i) **SPCL.**
- (j) **10 ENTER.**

(3) Set calibrator for a .1581 V, 1200 Hz output. TI indication will be between -9 and -11 dB.

(4) Repeat technique of (3) above using calibrator output settings and TI indications listed in table 13.

Table 13. SINAD Measurement

| Calibrator output settings | | Test instrument indications | |
|----------------------------|-----------|-----------------------------|-----|
| V | Frequency | Min | Max |
| .05 | 1200 Hz | -21 | -19 |
| .01581 | 1200Hz | -31 | -29 |
| .1581 ¹ | 80 kHz | -12 | -8 |
| .05 | 80 kHz | -22 | -18 |
| .01581 | 80 kHz | -32 | -28 |

¹Press TI **SOURCE FREQ** key and enter **40 kHz** using **DATA ENTRY** keys.

b. Adjustments. No adjustments can be made.

TB 9-6625-2271-50

17. Final Procedure

- a.** Deenergize and disconnect all equipment. Return switch settings to original positions.
- b.** Annotate and affix DA label/form in accordance with TB 750-25.

TB 9-6625-2271-50

By Order of the Secretary of the Army:

Official:

ERIC K. SHINSEKI
General, United States Army
Chief of Staff

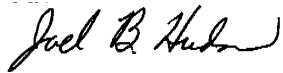

JOEL B. HUDSON
Administrative Assistant to the
Secretary of the Army
0020609

DISTRIBUTION:

To be distributed in accordance with Std. IDS No. RLC-1500, 11 May 1992,
requirements for calibration procedure TB 9-6625-2271-50.